



**Global Leader in High Security Information
End-of-Life Solutions for Over 50 Years**

Operation and Maintenance Manual

SEM Model 5146P Series



MAN-033 Rev 2 | Created 12-10-20 |

For service, parts, and customer support, contact us:

SECURITY ENGINEERED MACHINERY
5 Walkup Drive • Westborough, MA 01581
service@semshred.com
1-508-366-1488
www.semshred.com

DEFINITION OF NORMAL USE:

1. This paper shredder is suitable for the destruction of paper.
2. The cutting shafts, which are made of special hardened steel, are unaffected by small quantities of paper clips and staples. Depending on the shred size produced by the cutting head, small quantities of CDs, DVDs, credit cards, customer cards and disks can be partially destroyed. To determine whether your shredder is capable of shredding these kinds of data carriers, please check at www.semshred.com

SAFETY PRECAUTIONS:



Please read these operating instructions before putting the machine into operation and observe the safety precautions. The operating instructions must always be available.



CAUTION



Children must not operate the machine!



Do not reach into the feed-opening of the cutting head!



Long hair can become entangled in cutting head!



Take care of ties and other loose pieces of clothing!



Be careful of loose jewellery!

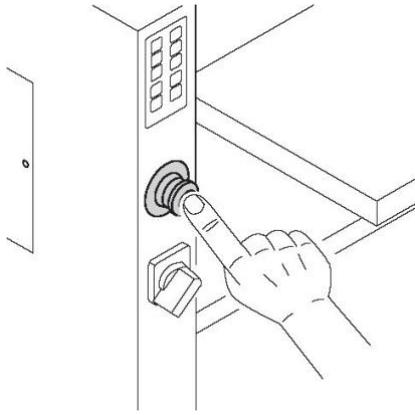

Quick stop - Press emergency stop!

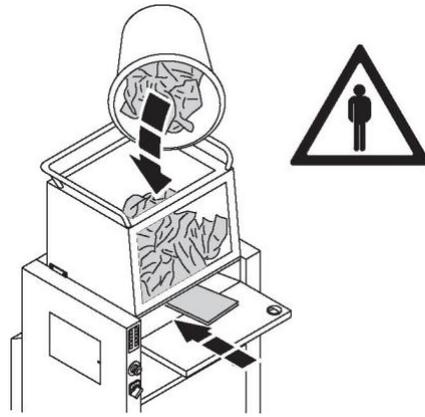

This machine is constructed for "one man operation" only!

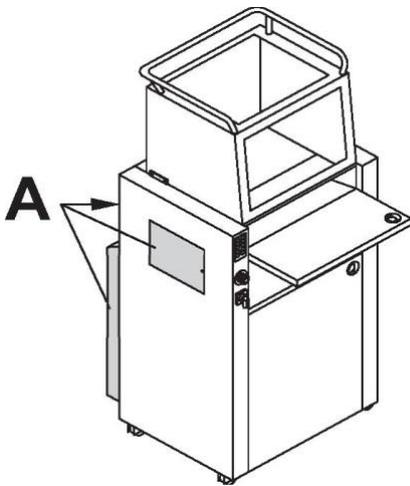

All components which could endanger the operator are covered by a guard (A).

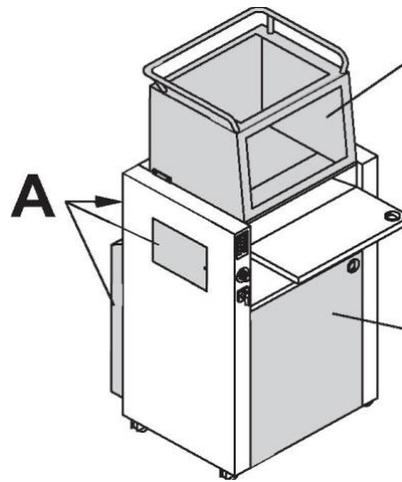

Do not operate the machine without the following safety devices:
Panels (A) tightly screwed
Feeding hopper (B) and door (C) which are secured by switches.

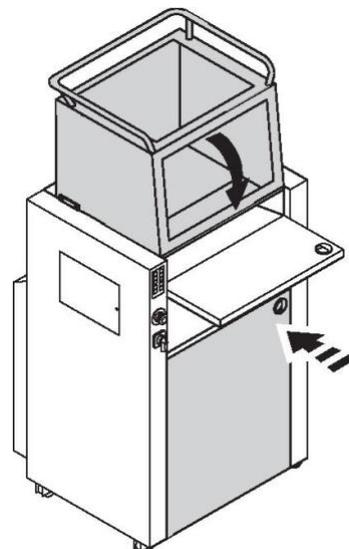

3 Machine operates only when the door and feeding hopper are closed.

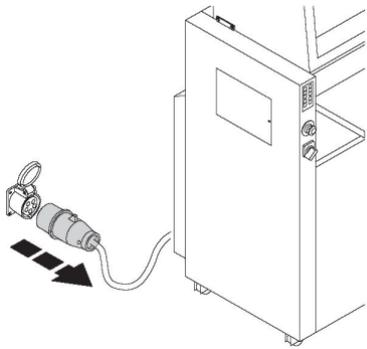

Remove the plug before cleaning the machine!

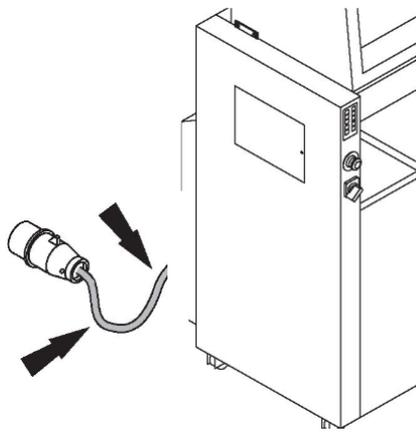

Protect main cable against heat, oil and sharp edges!

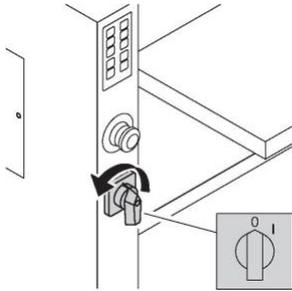

When not in use for a long period of time: turn switch off.

INSTALLATION :

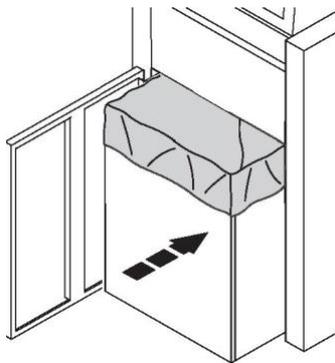

Insert the enclosed plastic bag in the waste cart

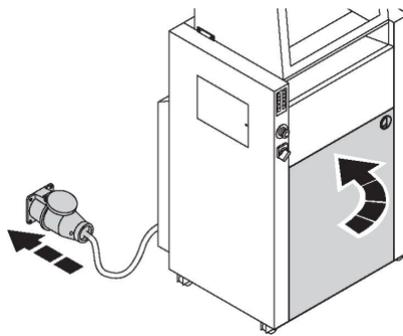

Close the door. Plug into the wall socket

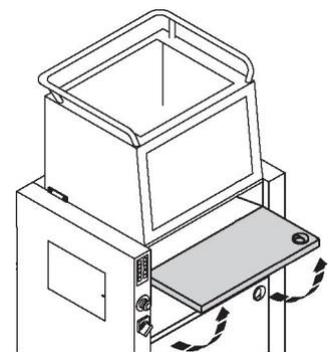

Pull out Feed Tray

Starting the machine.

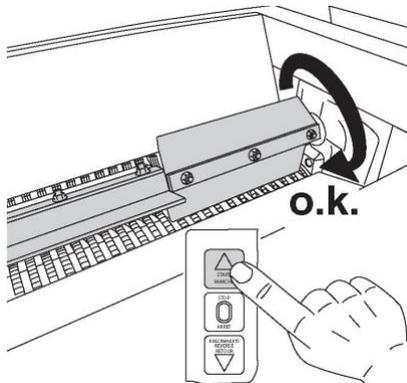

Check the rotating direction

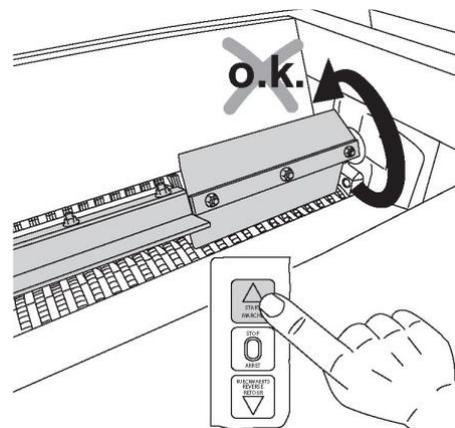

Is the wing shaft turning in the wrong direction?
Changes to the rotating direction must be done by an electrician.

OPERATION

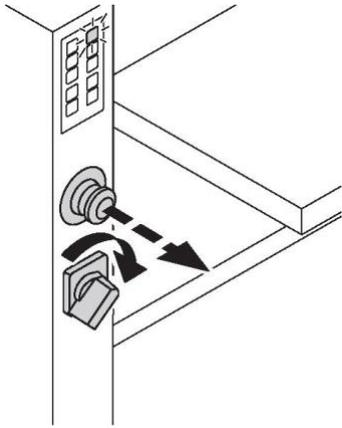

Main switch is on " I ".
Emergency button is pulled out.

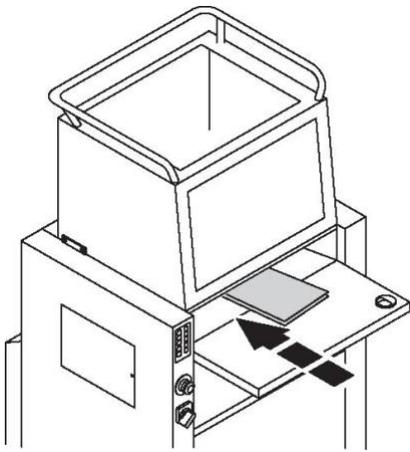

Automatic start/stop when feeding paper from the front

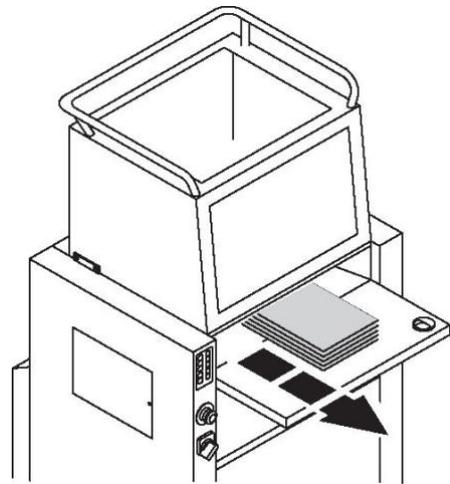

Automatic stop and reverse if too much paper is inserted.

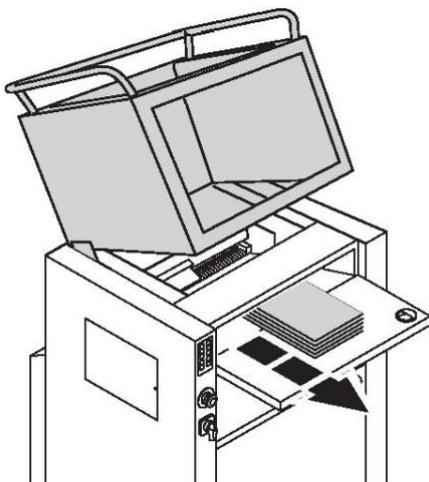

Remove paper. If necessary open the feeding hopper. Re-feed the paper in smaller quantities.

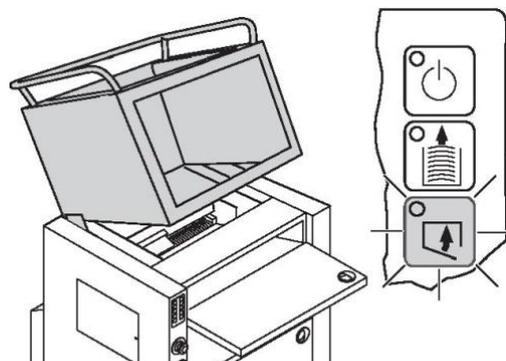
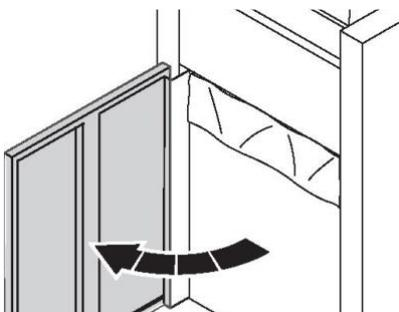
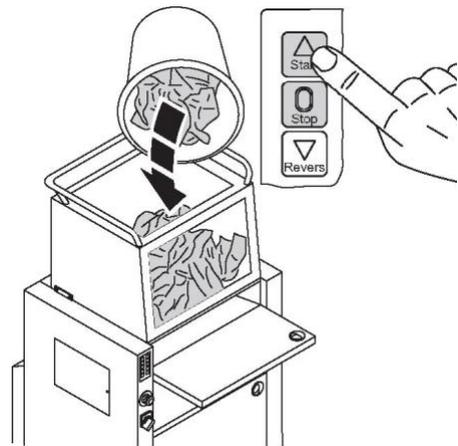

op.

Stops automatically when door is opened.

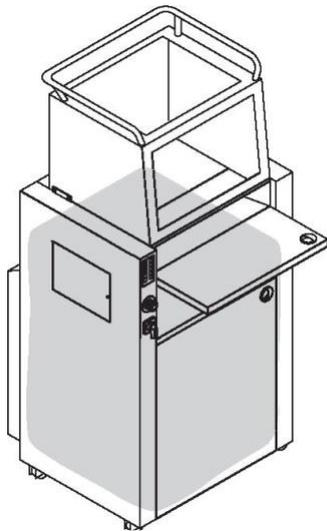

Stops automatically when feeding hopper is opened

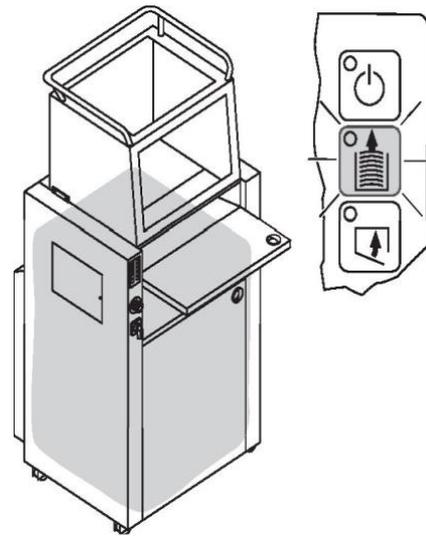

Stops automatically when plastic bag is full.

The "bag full" indicator lights are on. Replace bag.

SYSTEM LUBRICATION

For systems that **DO NOT INCLUDE** an AUTO OILER, the operator can "Manually" oil the cutting head.

To perform this task, "Squirt" shredder lubricant on a piece of paper as demonstrated in the picture below.

Cover the oiled sheet with a second sheet of paper (in effect creating an "oil sandwich") and simply feed the paper into the system. The oil from the sheets will then be dispersed onto the cutting head.

For added convenience, SEM offers "lubricant sheets" as an option and are noted in the accessories page in this operators manual.

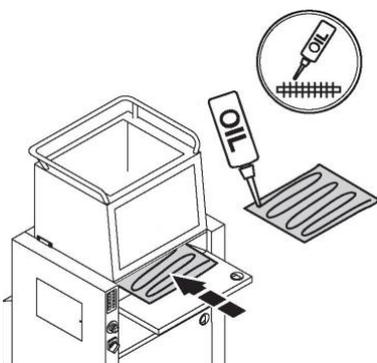

If the sheet capacity reduces or after the bag is emptied we recommend that you oil the shredding mechanism!

POSSIBLE MALFUNCTIONS : Machine will not start

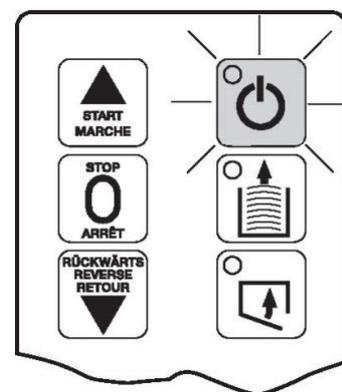
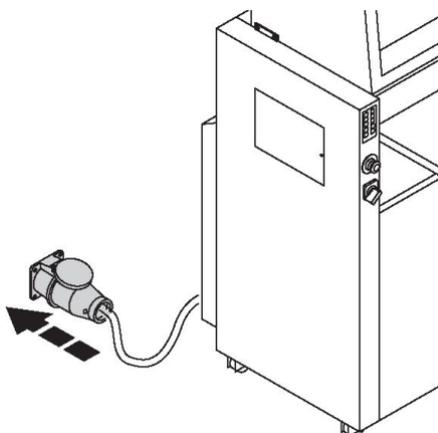

Is the machine plugged in?

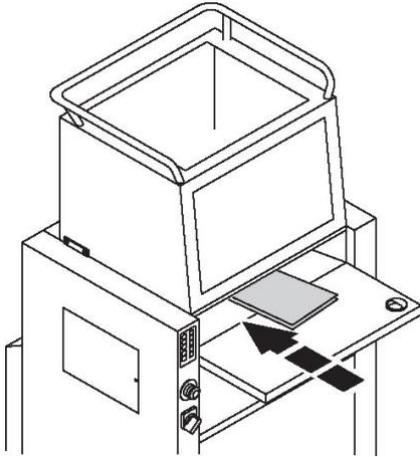

Is it ready for operation
(i.e. is the green LED illuminated)?

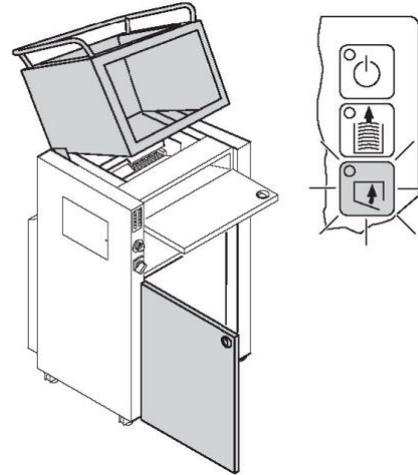

Is the paper fed into the centre of the feed opening (photo cell)?

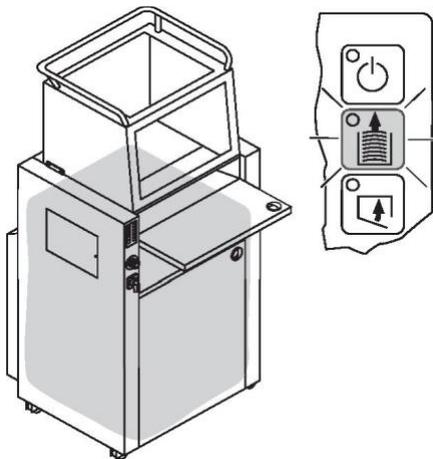

Door open, feeding hopper tilted?

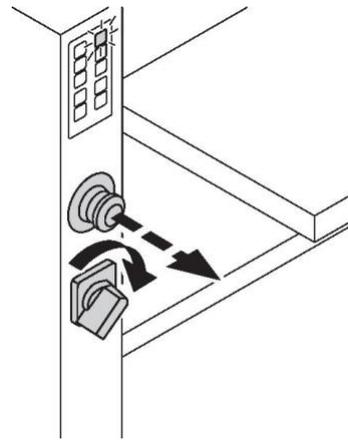

Plastic bag full ?

Main switch is on " I ". Emergency button is pulled out.

Malfunctions - Continued

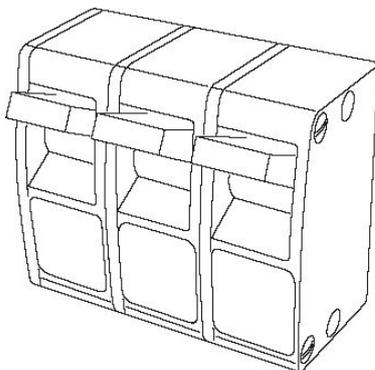

No performance?
An electrician must examine the phases.

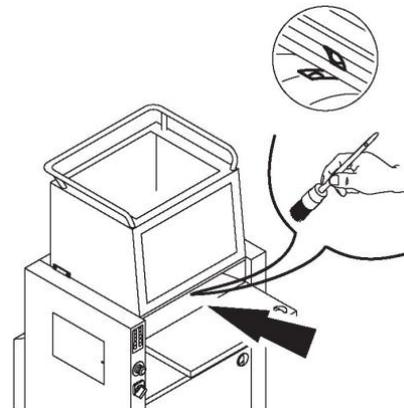

Machine stops !
Overload protection. Please let the machine cool down.



Machine will not stop!
Clean the photo cell with a small brush

LUBRICATING OIL

SEM ITEM	Oil per Case or Packet	SEM Shredders Supported
647OILHV	4 GALLONS For use with systems with Auto Oilers	FOR USE with systems that INCLUDE an AUTO OILER Specially formulated CONVENTIONAL Shredder Oil.
647OIL-ECO4	4 GALLONS For use with systems with Auto Oilers	FOR USE with systems that INCLUDE an AUTO OILER Specially formulated ECO-FRIENDLY (BIO-BASED) Shredder Lubricant.
649OIL8HV	8 PINTS For use with "Manually" Oiled Systems	FOR USE with systems that DO NOT INCLUDE an AUTO OILER Specially formulated CONVENTIONAL Shredder Oil
647OILSHEET10	10 SHEETS For use with "Manually" Oiled Systems	FOR USE with systems that DO NOT INCLUDE an AUTO OILER Specially formulated Bio-Based LUBRICANT SHEETS

WASTE COLLECTION BAGS

SEM ITEM	Bags per Case	SEM Shredders Supported
637SB229A	100	1121, 1125, 1324 S and 1324P Series
640SB130A	50	1324PWO, 2125, 2226, 244, 344 and 1201 Series
639SB140A	50	2331, 3130, 3140, 4140, 266, 5140, 5141, 5146 Series
642SB190A	25	<i>6040, 800 and 7050 Series</i>
638SB138A	50	<i>Disintegrator Models 200 and DS200 and 2125, 1324C/3wo</i>
755BAG3MILA	50	<i>Disintegrators with F-Series Air System</i>
638ASB0201	50	<i>0201 OMD</i>
640ASB0202	50	<i>0202 OMD</i>

OTHER SHREDDER ACCESSORIES:

- REPLACEMENT CAP and STRAW for Auto Oiler Systems.
- REPLACEMENT Oil Brackets
- REPLACEMENT Waste Collection Bins

Since there are different waste collection bins and accessories for each specific model, to insure that you are requesting the appropriate item, please contact SEM customer care at 800-225-9293 or service@semshred.com. Please have the system model number and serial number available. The SEM Customer Care dept will be able to provide the appropriate item number and cost.

TECHNICAL INFORMATION

POWER: 400V, 3-PHASE, 10 A; 230V, 3-PHASE, 30 A

NOISE: The sound level at the work place is less than the EN 13023 standard's maximum permissible level of 70 dB(A).

Subject to alterations without notice



NOTE: It is very important to oil frequently when shredding CD/DVDs

REGULATORIES



These machines are approved by independent safety laboratories and is in compliance with the EC-regulations 2014/35/EU and 2014/30/EU.



The Manufacturer of these shredders, Krug + Priester has a certified quality management system according to DIN EN ISO 9001:2008 and a certified environmental management system

Sound Level Information:

EC- DECLARATION of CONFORMITY

2006/42/ EC Machinery directive, 2004/108/EG EMV Electromagnetic compatibility directive

Applied harmonised standards in particular: EN 60204-1; EN 55014-1; EN 55014-2; EN 61000-3-2; EN 61000-3-3; EN ISO 12100; EN ISO 13857; EN 13023; EN 13849

COMMITMENT TO THE ENVIRONMENT

RECYCLING

As demonstrated by our ISO 14001 Certification and the attainment of the world recognized prestigious BLUE ANGEL Certification, both SEM and our Manufacturing Partners are committed to the environment.

We want to remind you to please remember to respect your local regulations and return your non-working electrical equipment to an appropriate waste disposal centre. To assist in this, the packaging material used in our shredders is recyclable. Dispose of the packaging in an environmentally friendly manner and make it available for the recyclable material collection-service. To help with the disposal of an end-of life shredder, it is designed so that it can be dismantled with any standard tool kit. All joining points are easily accessible and as such clearly visible.

Please think of the environment and dispose shredded CDs, cards and other data medium separately from shredder paper. Thank you!



**Global Leader in High Security Information
End-of-Life Solutions for Over 50 Years**

For service, parts, and customer support, contact us:

SECURITY ENGINEERED MACHINERY

5 Walkup Drive • Westborough, MA 01581

service@semshred.com

1-508-366-1488

www.semshred.com

Follow us on social media:

 Facebook: <https://www.facebook.com/semshred>

 Twitter: <https://twitter.com/semsecure>

 LinkedIn: <https://www.linkedin.com/company/security-engineered-machinery>

 Youtube: <https://www.youtube.com/user/datadestruction>